

ASSEMBLY INSTRUCTIONS

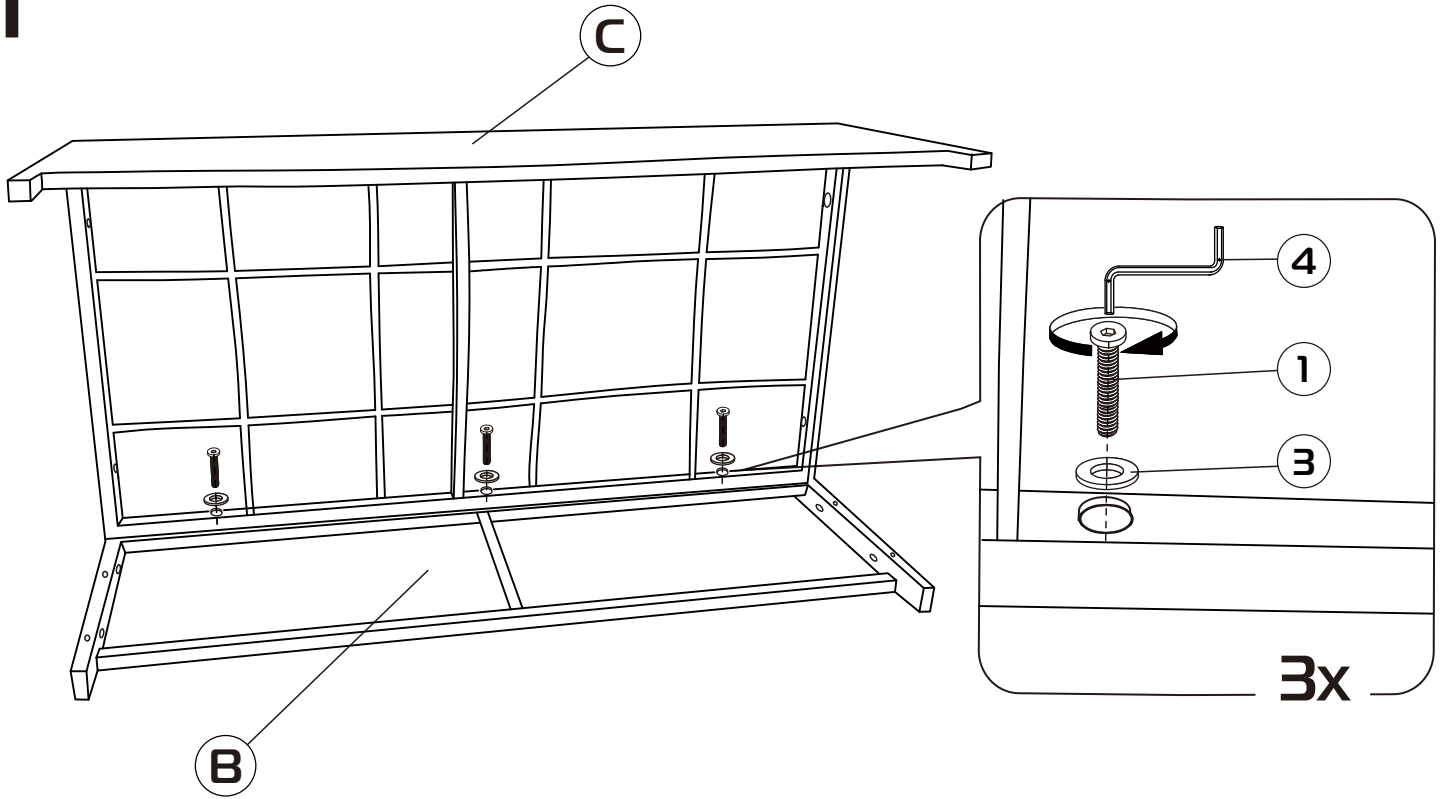

1



2

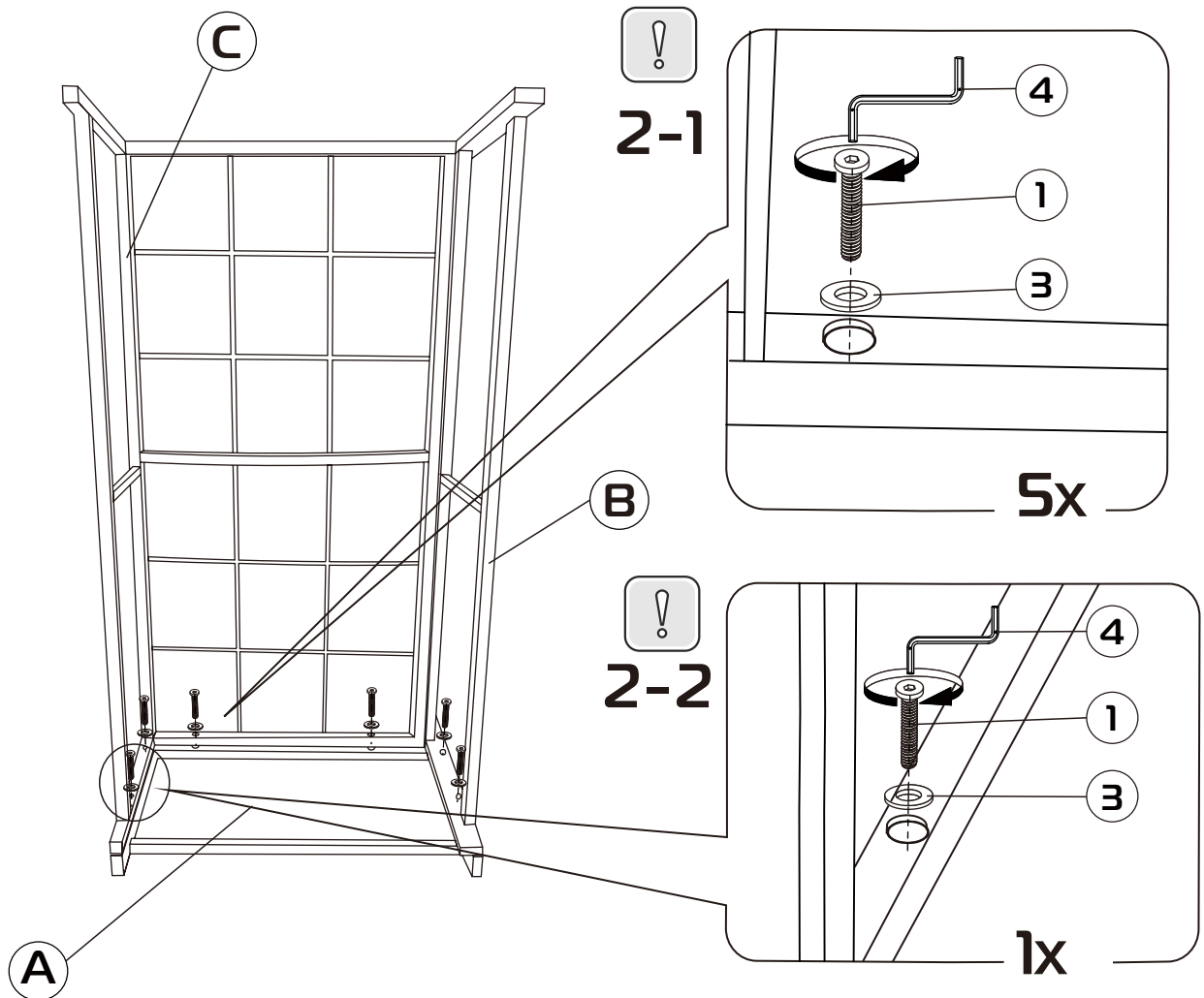

3

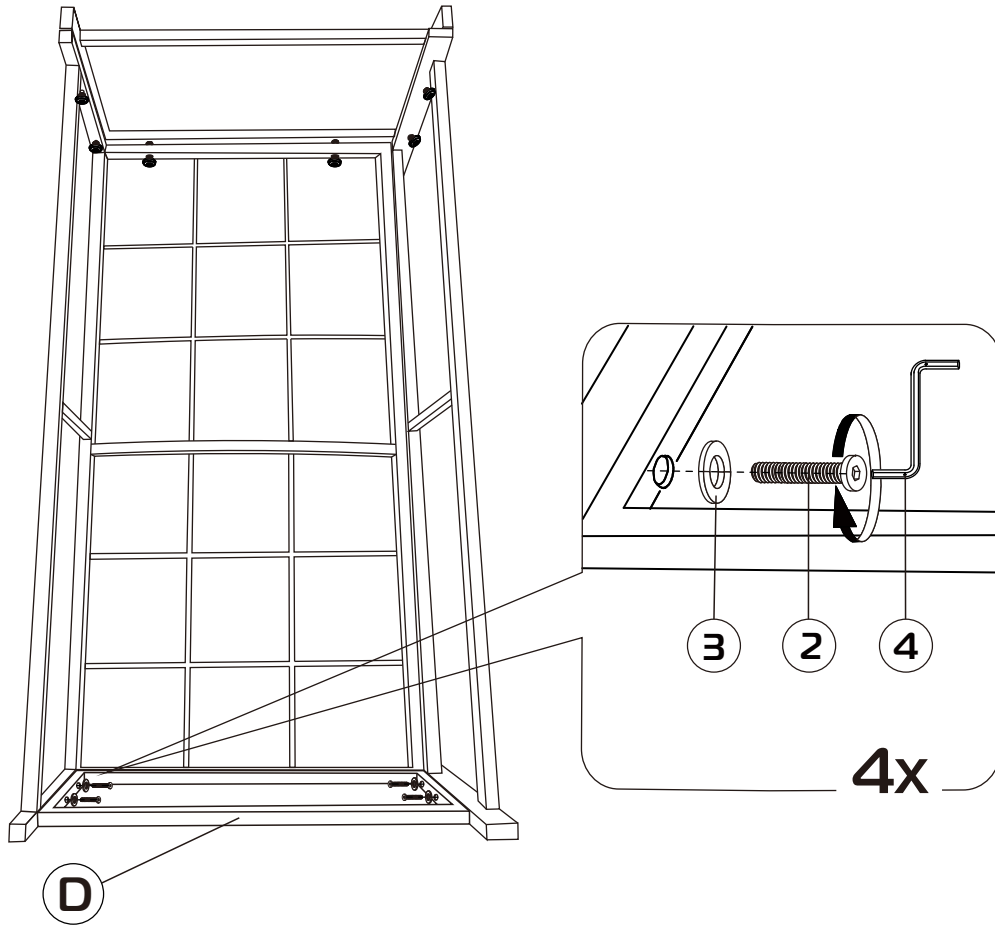

4

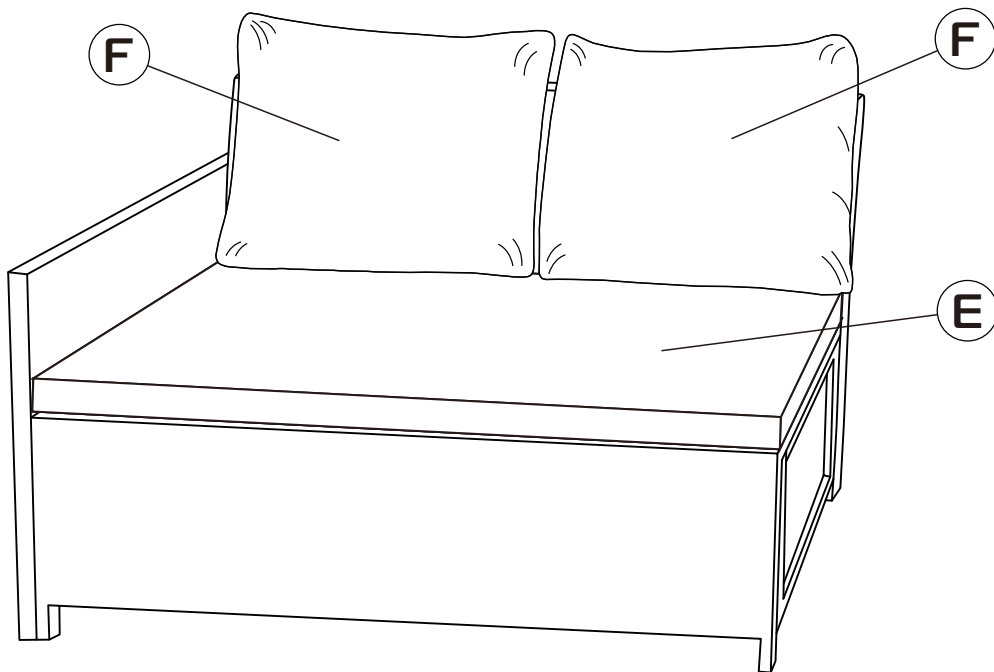

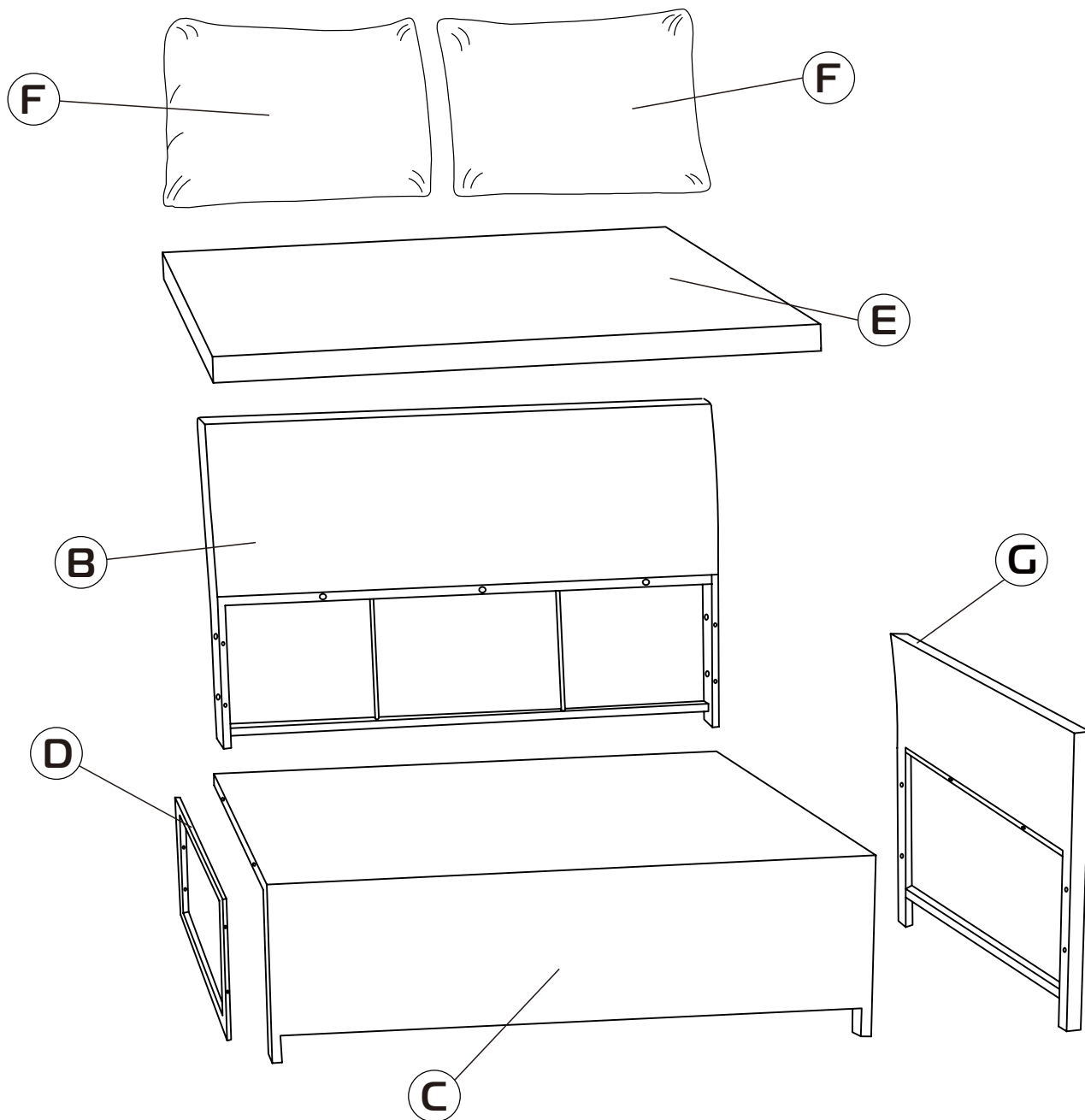

B -x1 **C** -x1 **D** -x1 **E** -x1 **F** -x2 **G** -x1

1:1

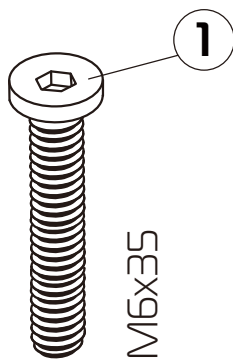

x9

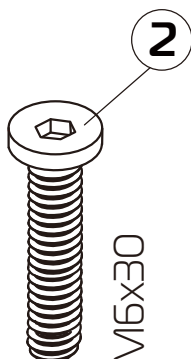

x4

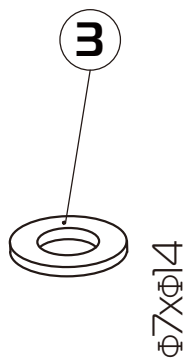

x13

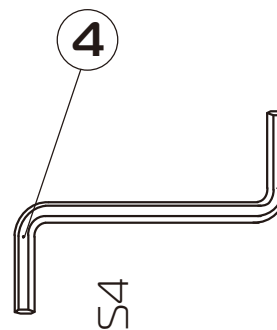

x1



1

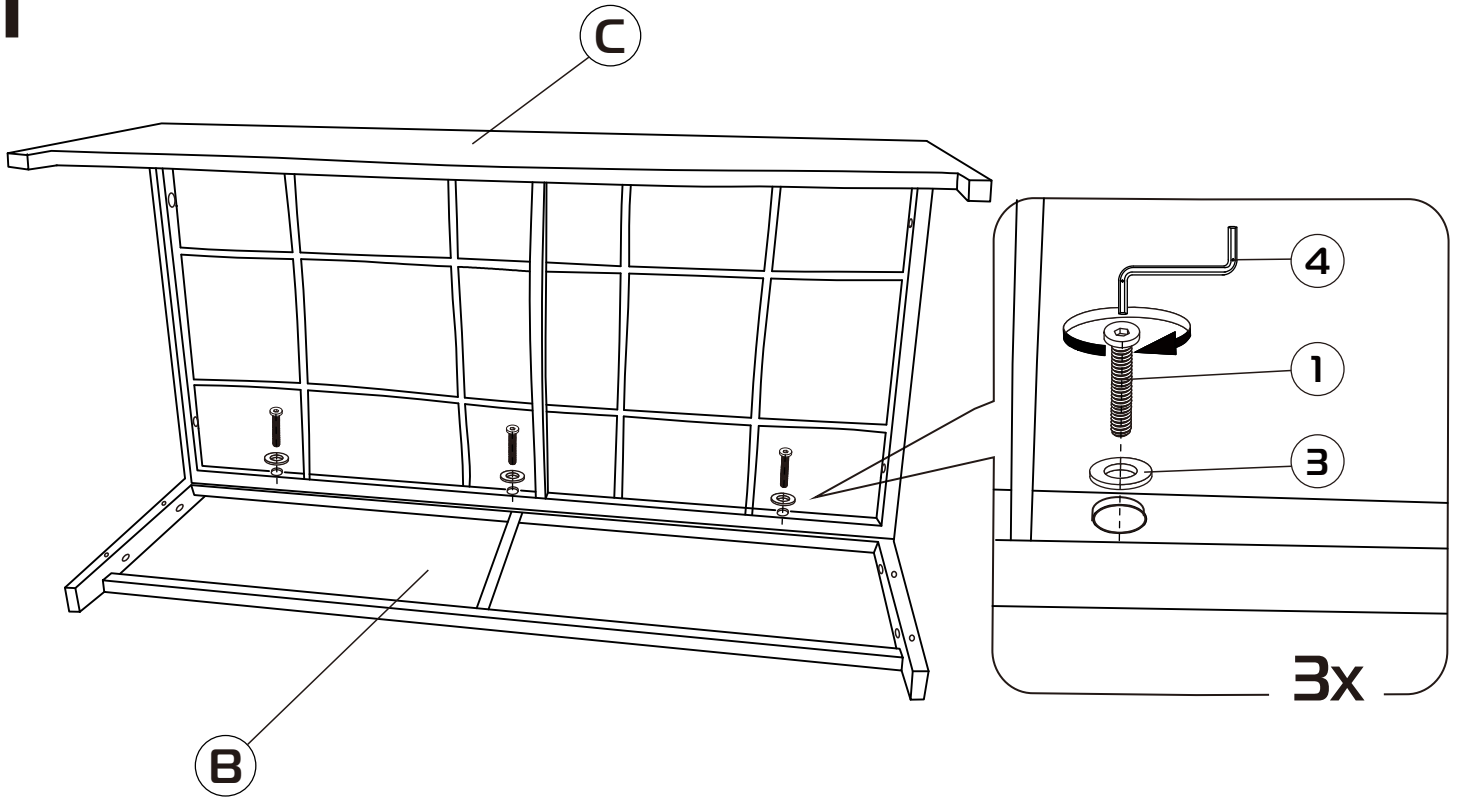

2

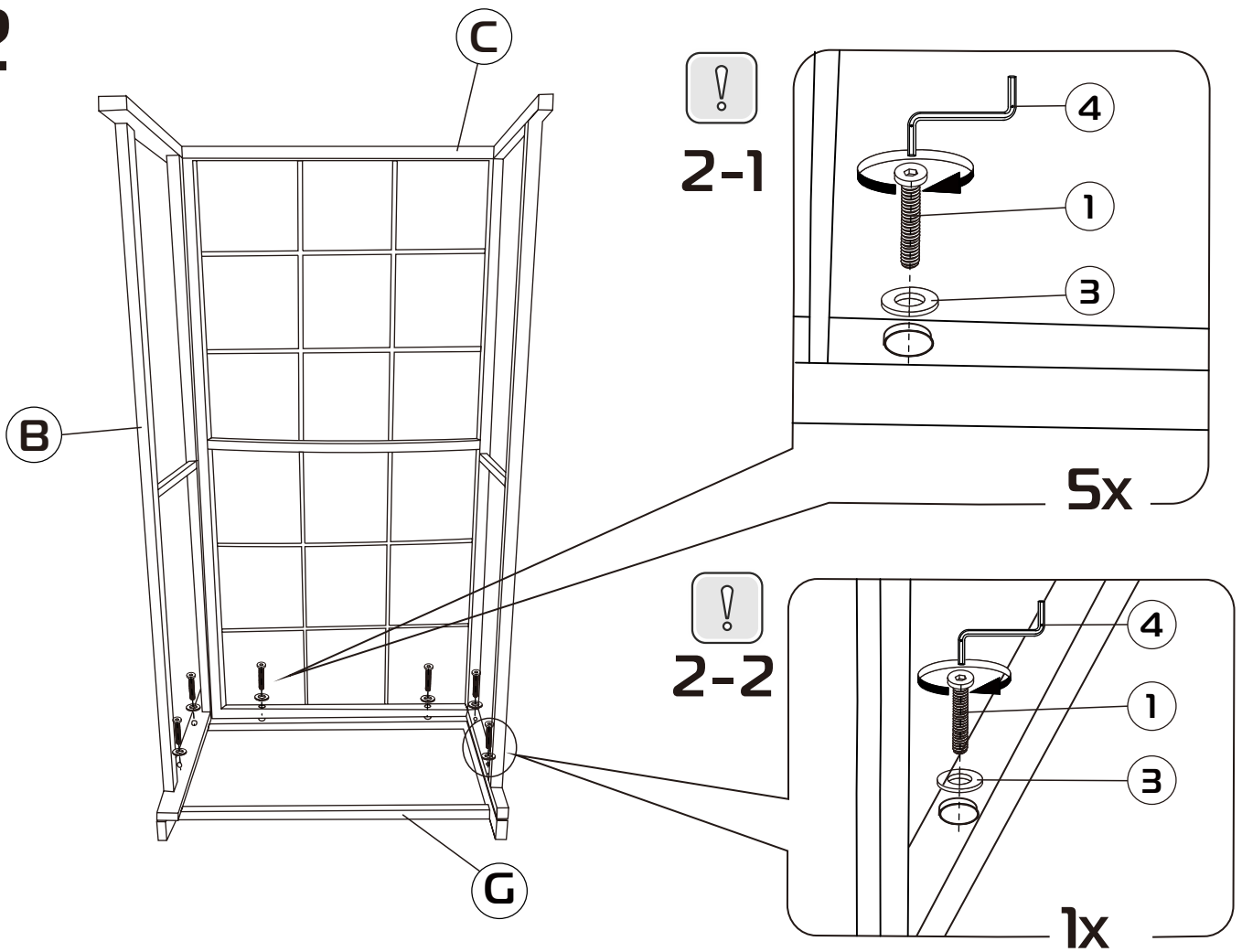

3

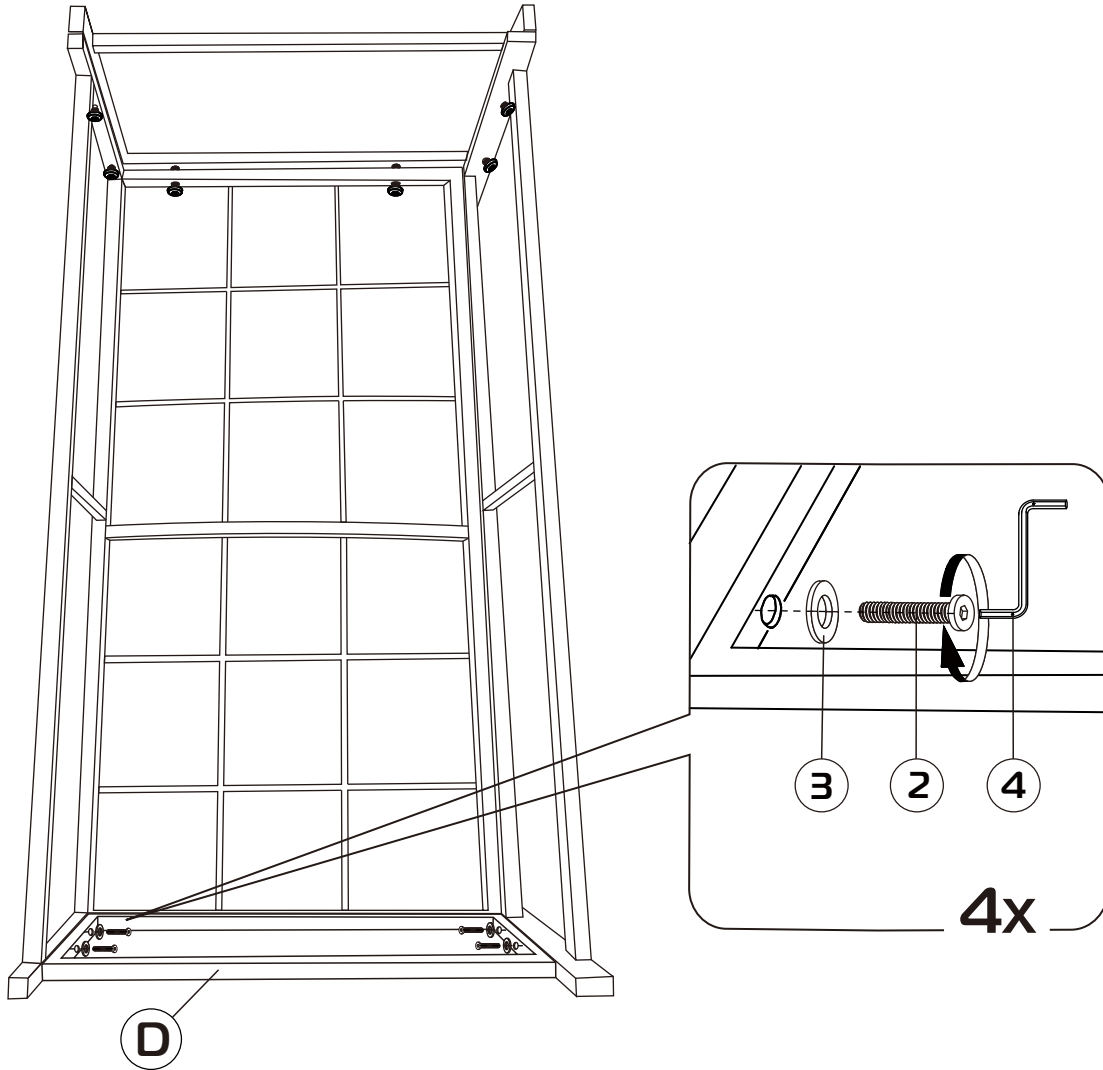

4

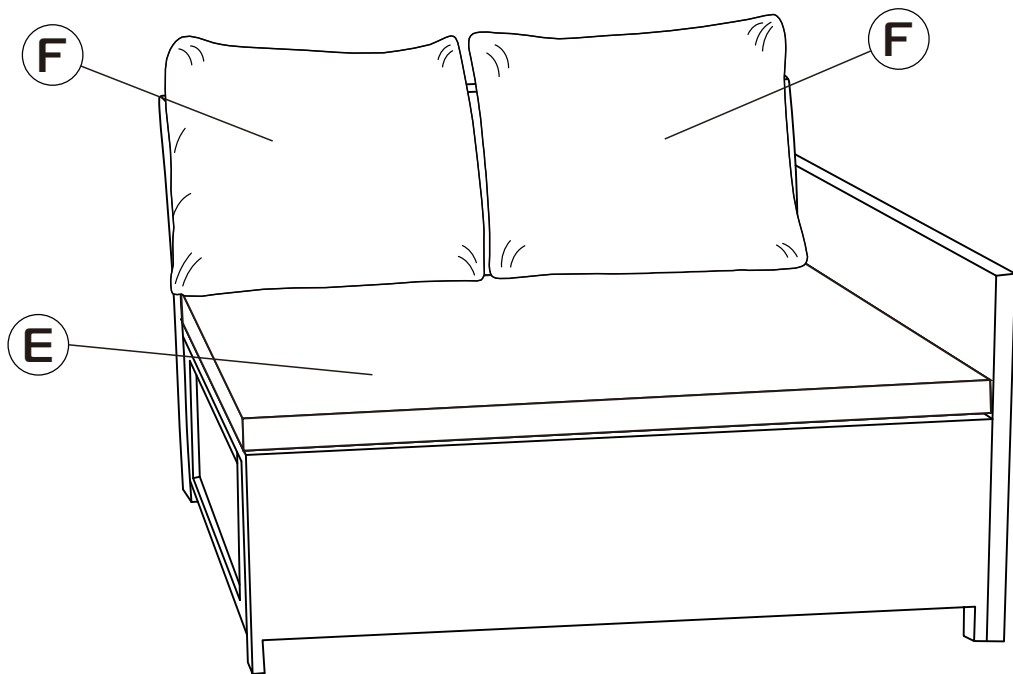

Параметры 1

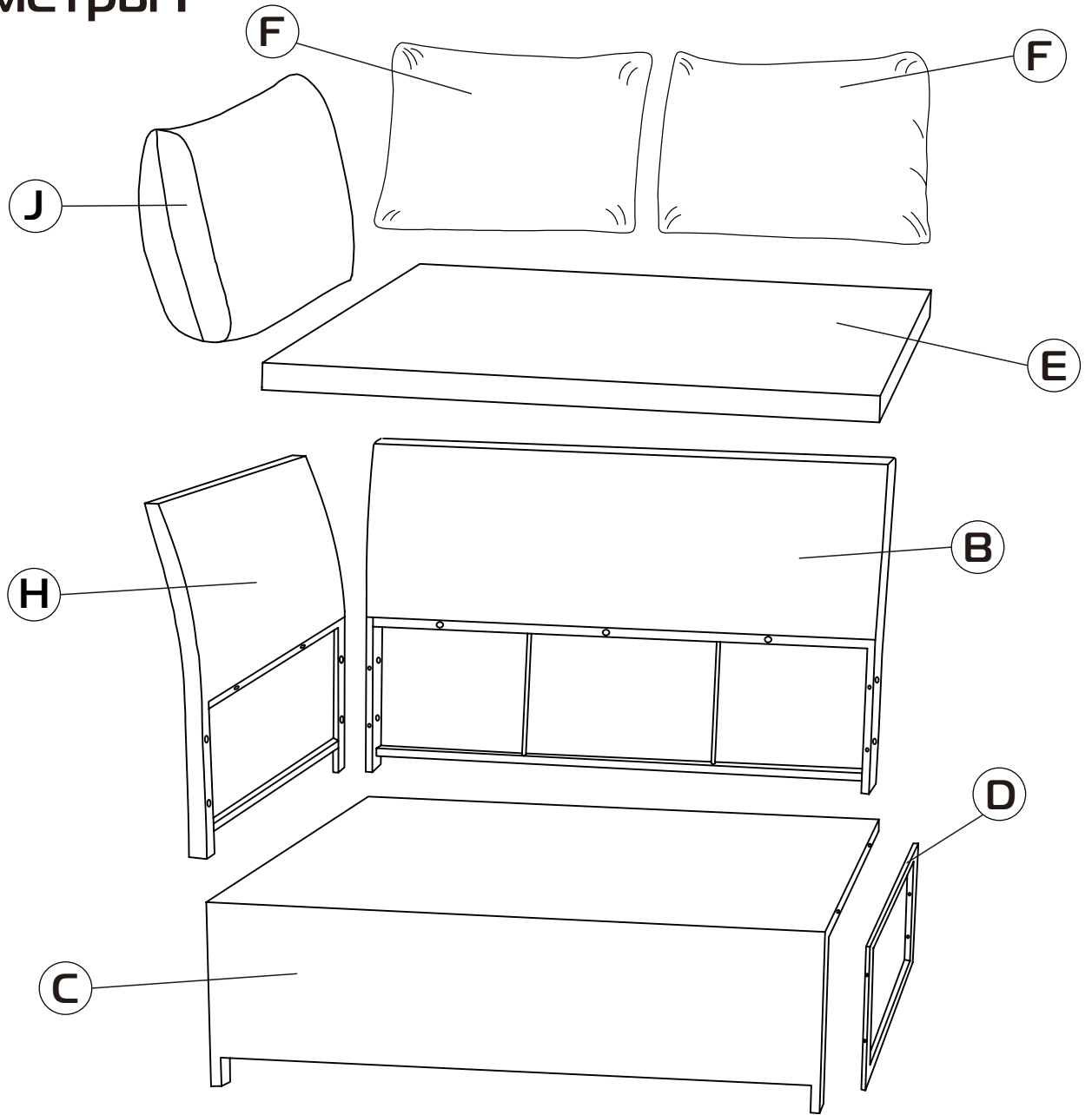

Ⓑ -x1 Ⓒ -x1 Ⓓ -x1 Ⓔ -x1 Ⓕ -x2 Ⓖ -x1 Ⓙ -x1

1:1

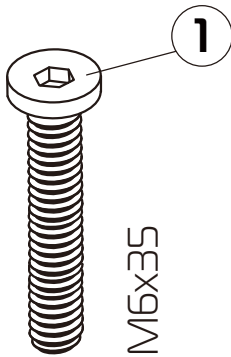

x9

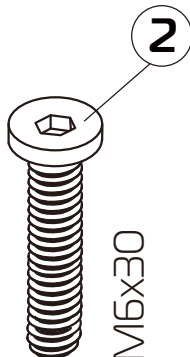

x4

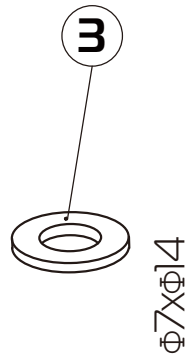

x13

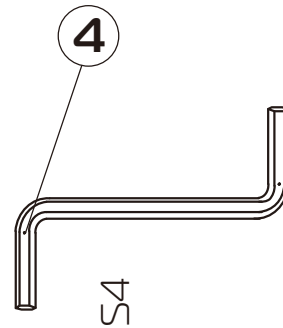

x1



1

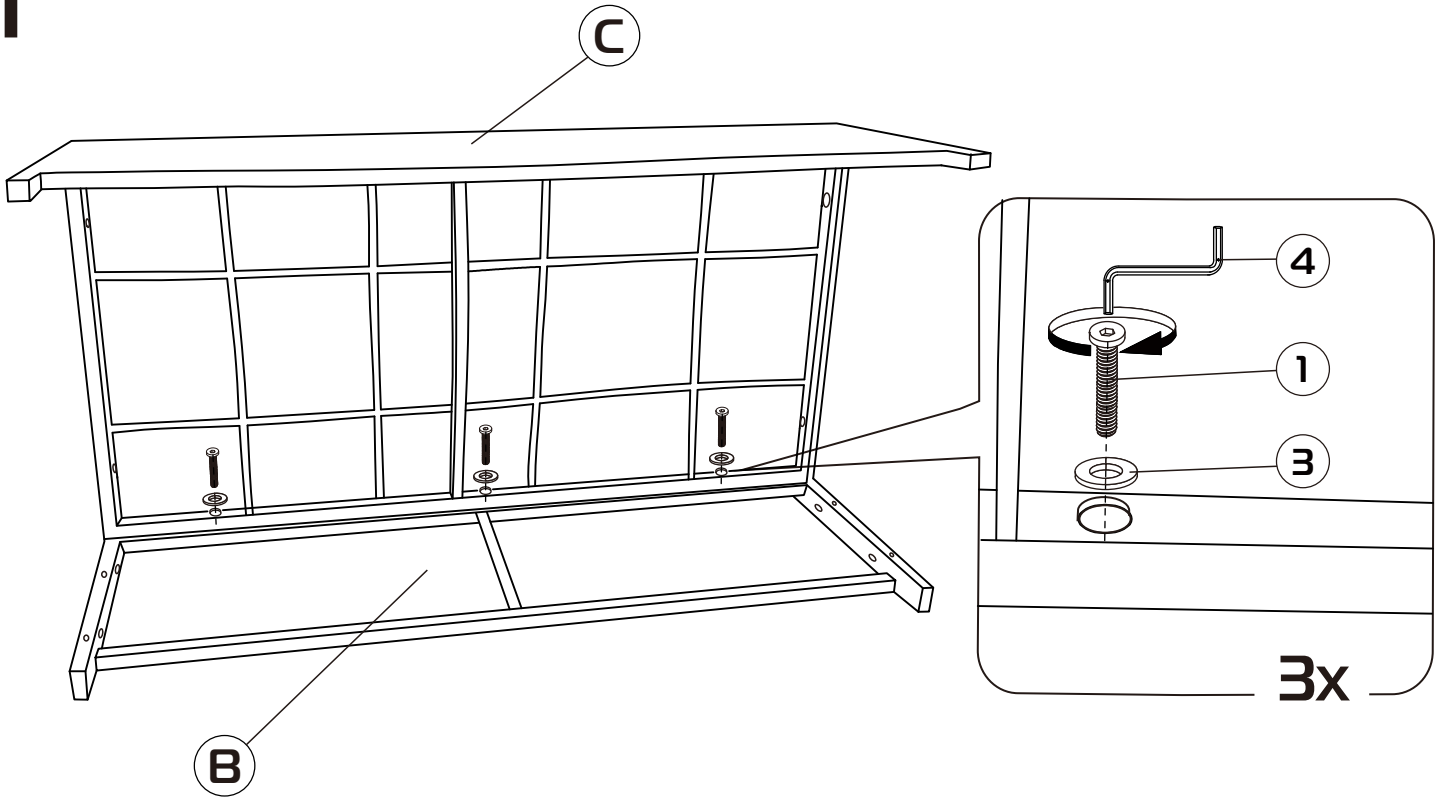

2

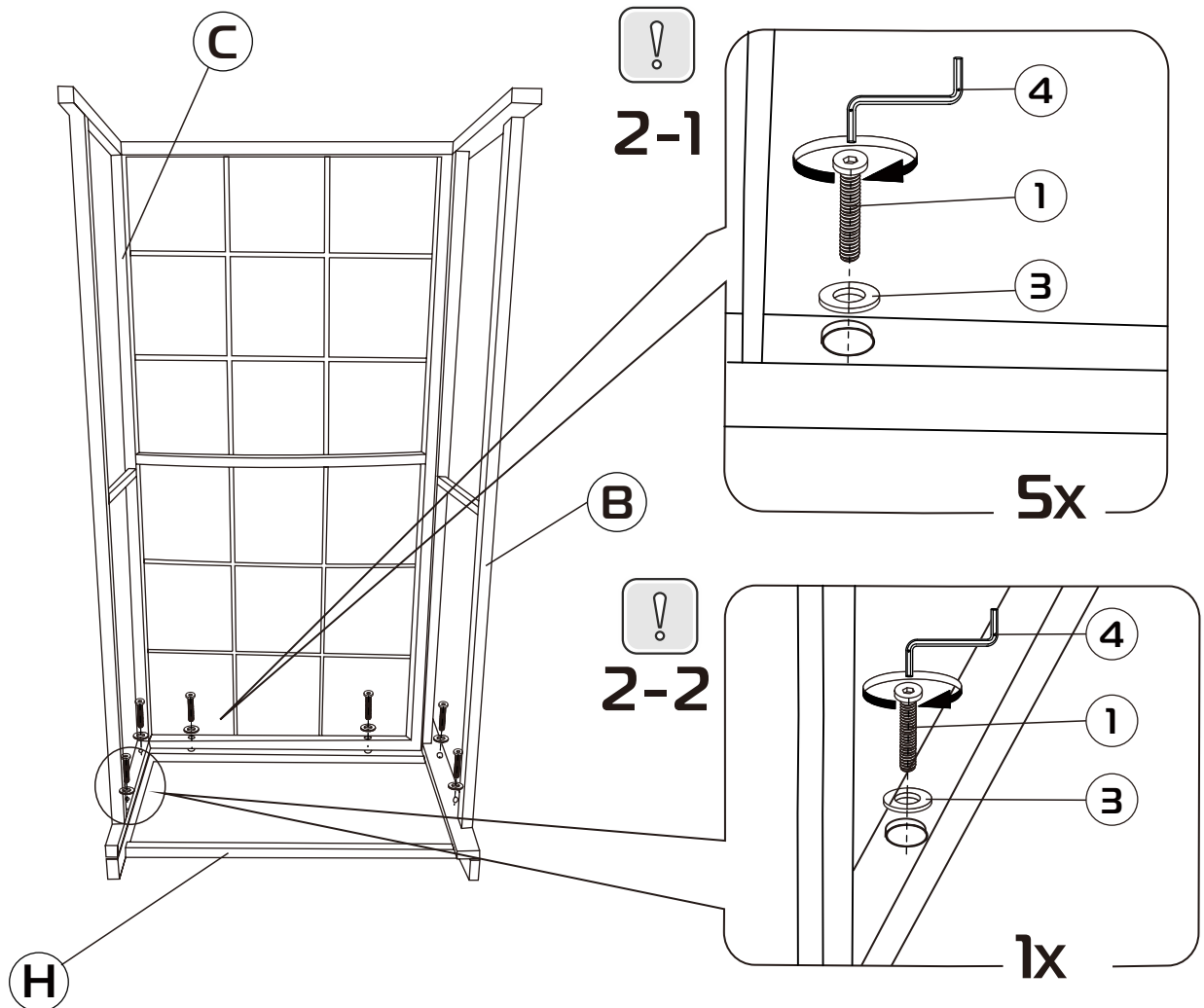

3

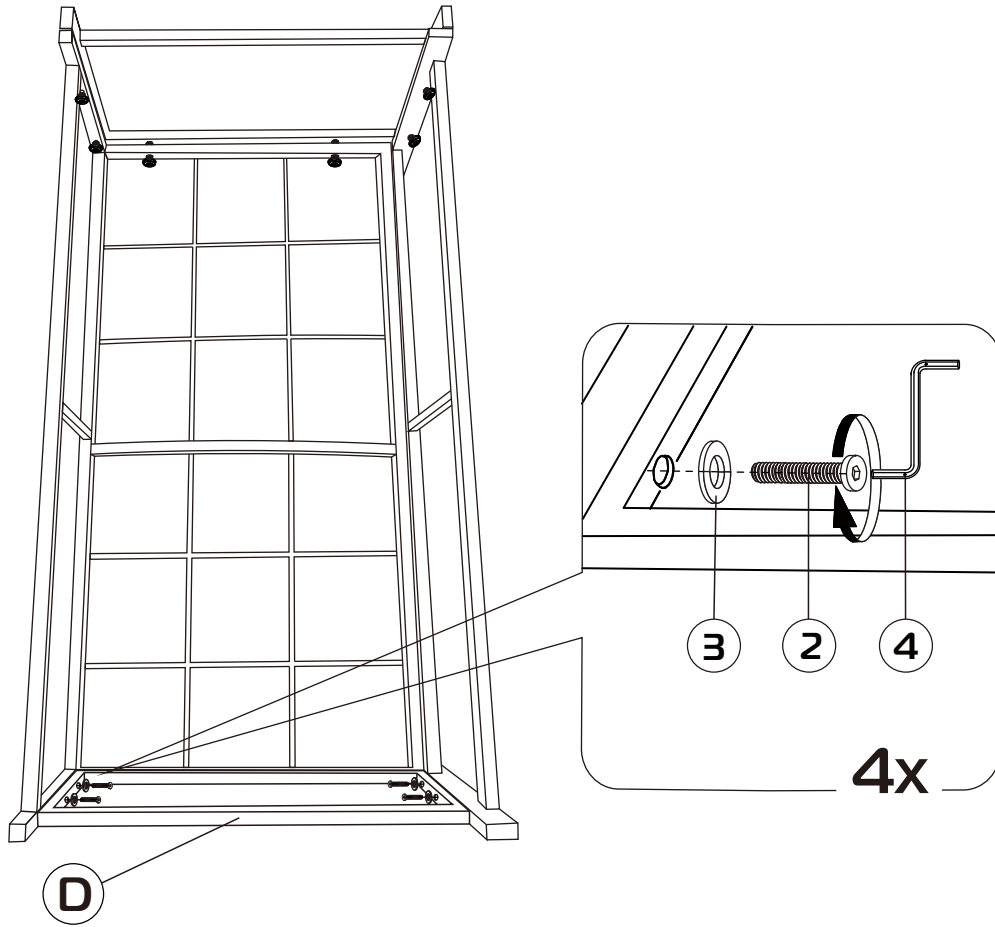

4

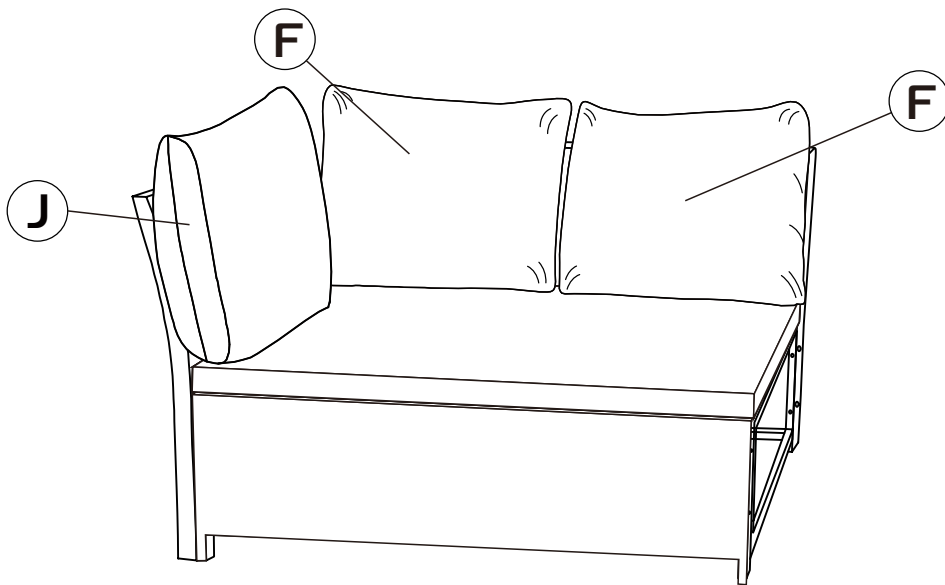

1:1

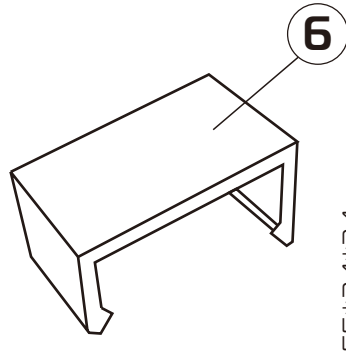

55*34*34mm

x4



1

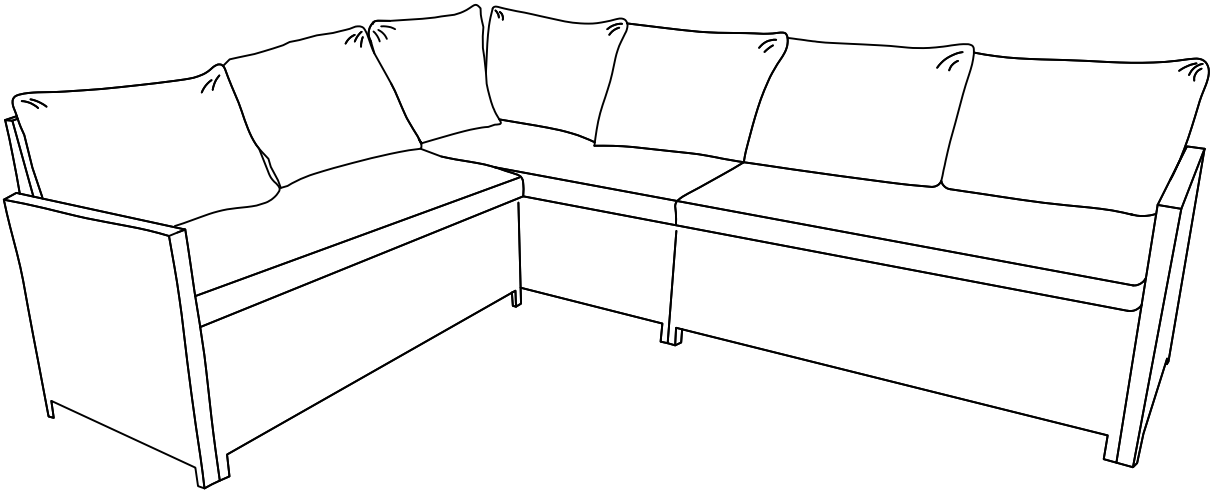
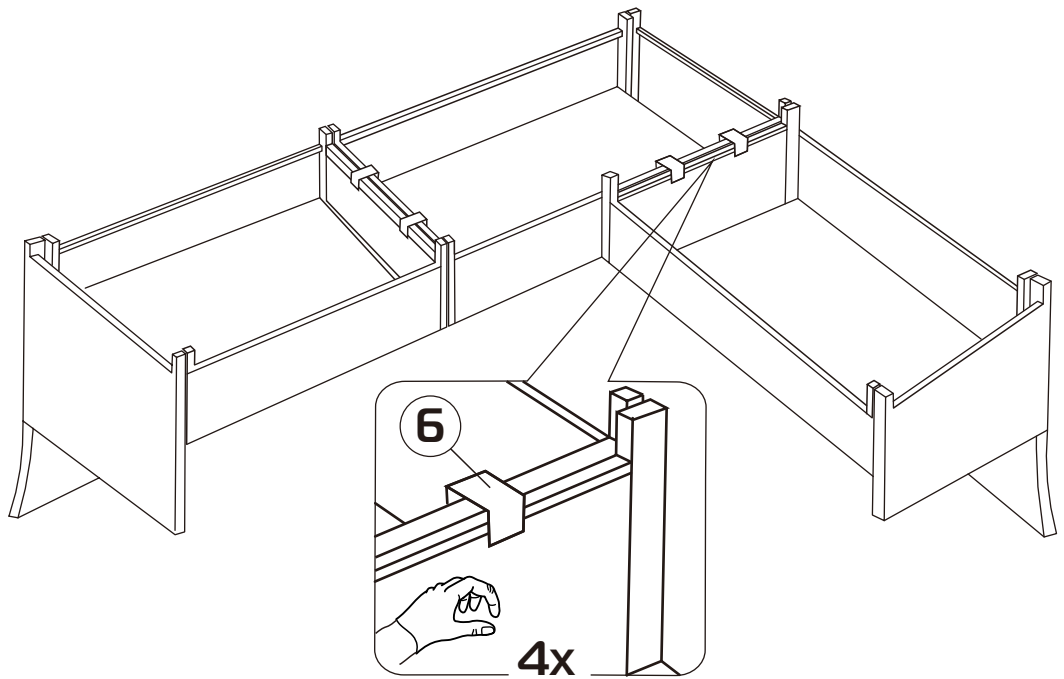

Параметры 2

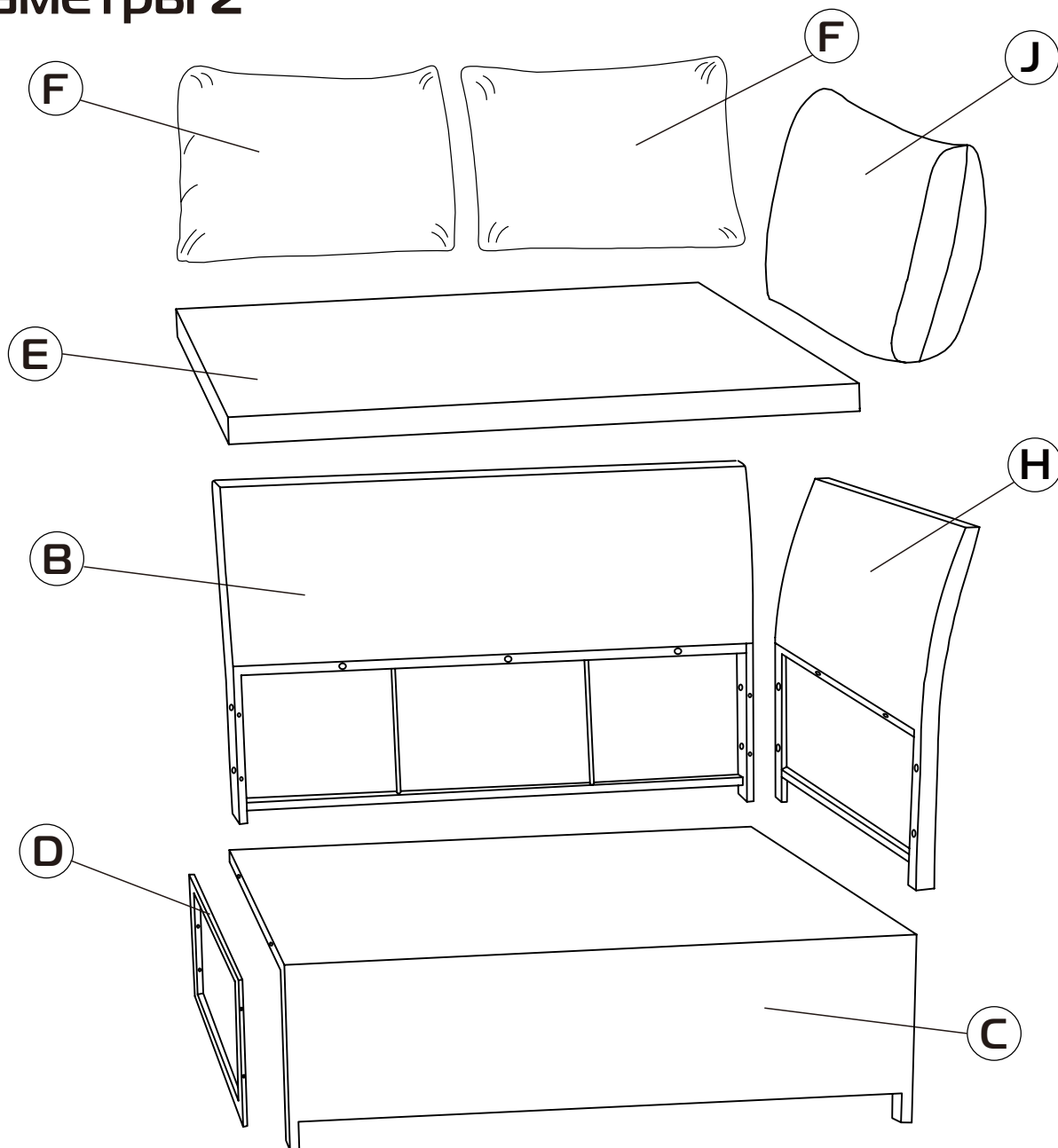

Ⓑ -x1 Ⓒ -x1 Ⓓ -x1 Ⓔ -x1 Ⓕ -x2 Ⓖ -x1 Ⓙ -x1

1:1

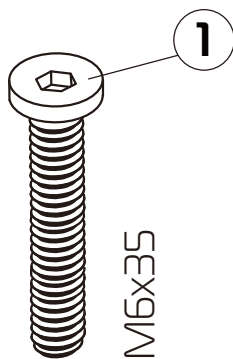

x9

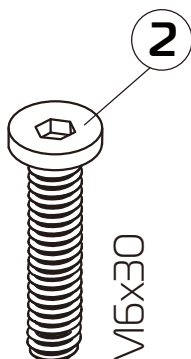

x4

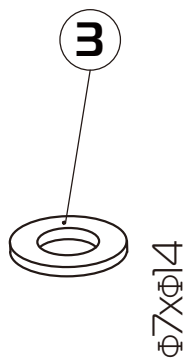

x13

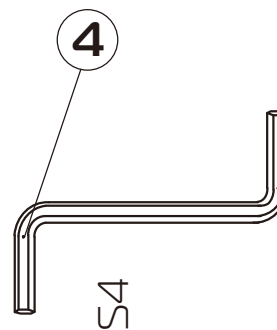

x1



1

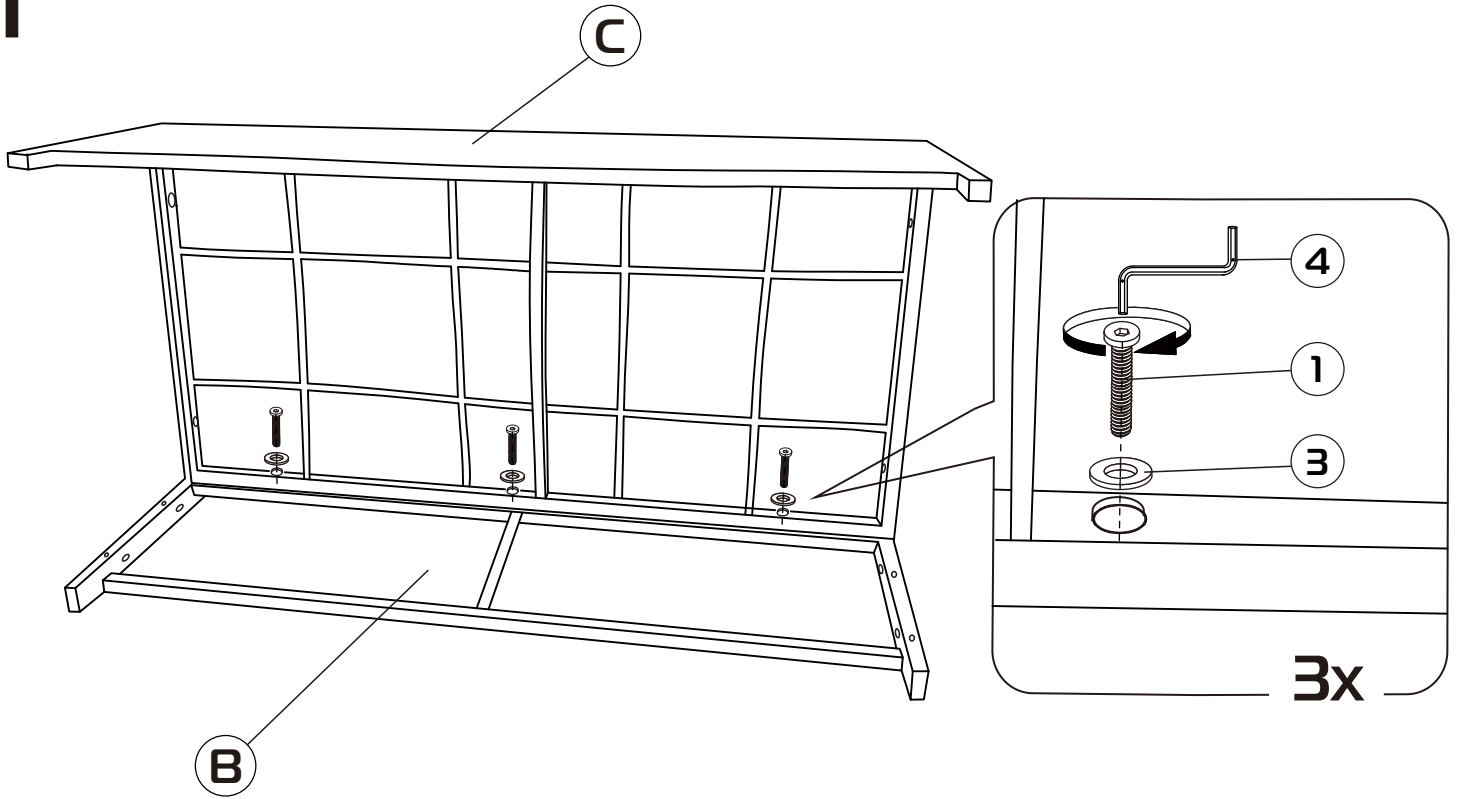

2

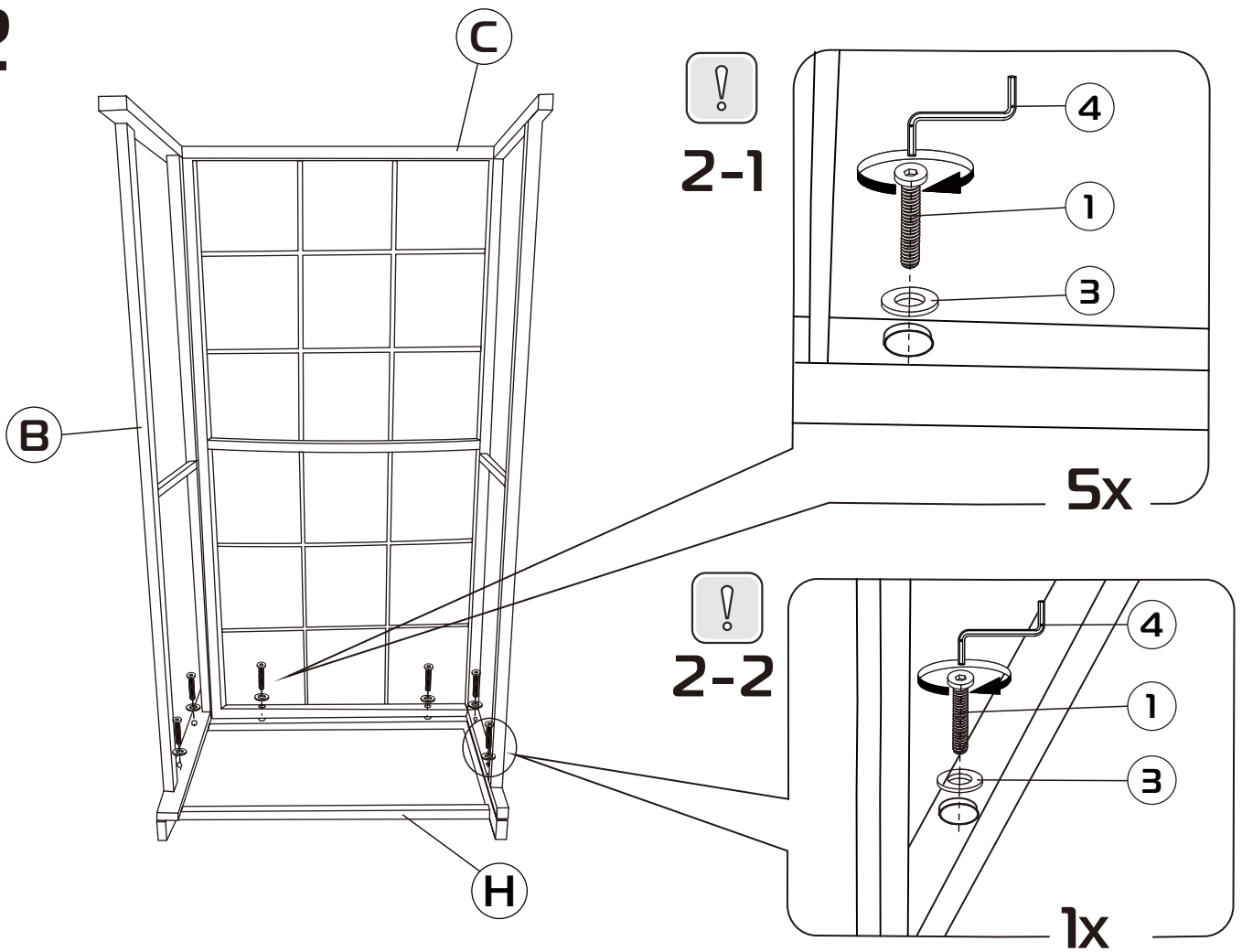

3

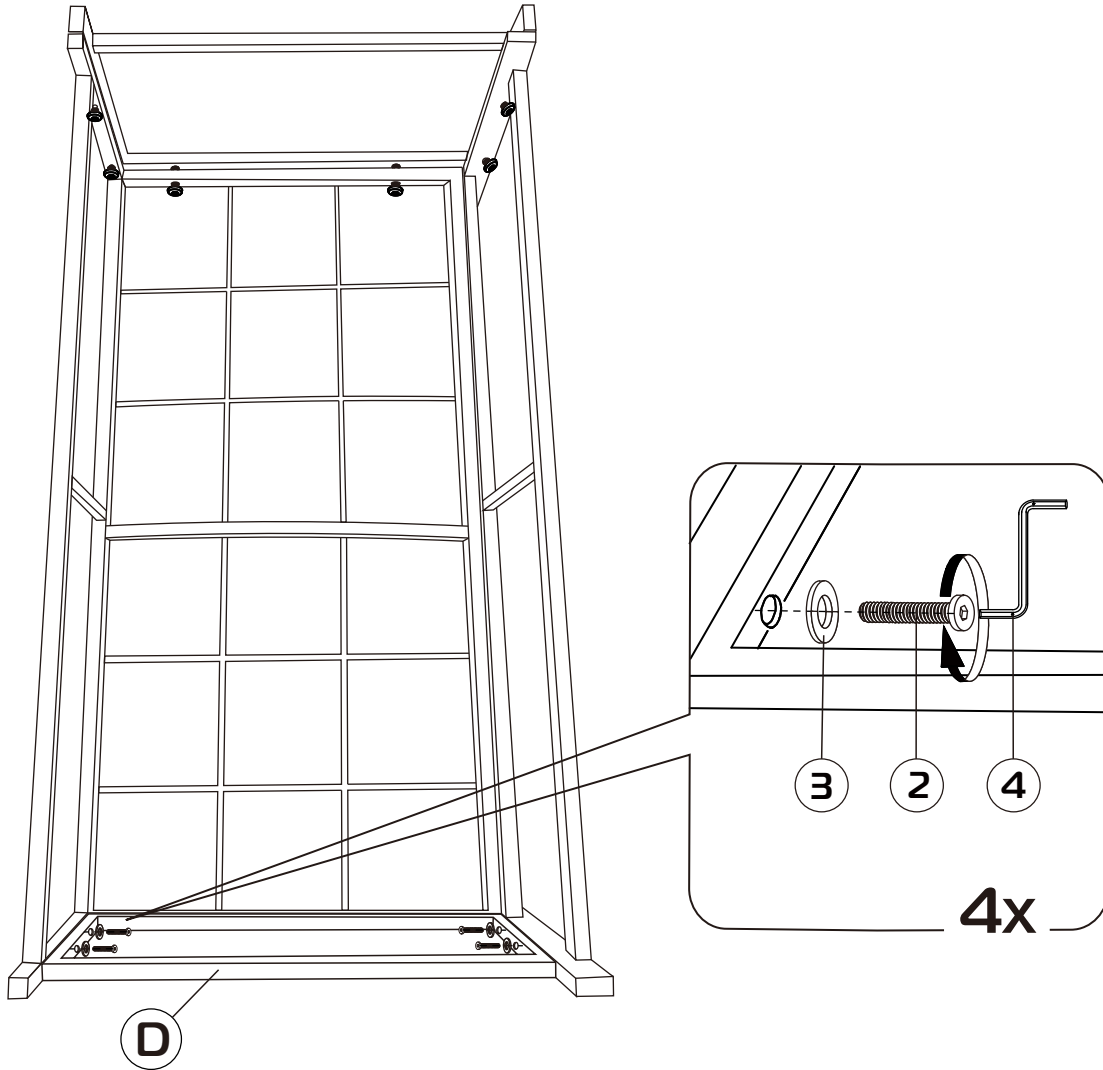

4

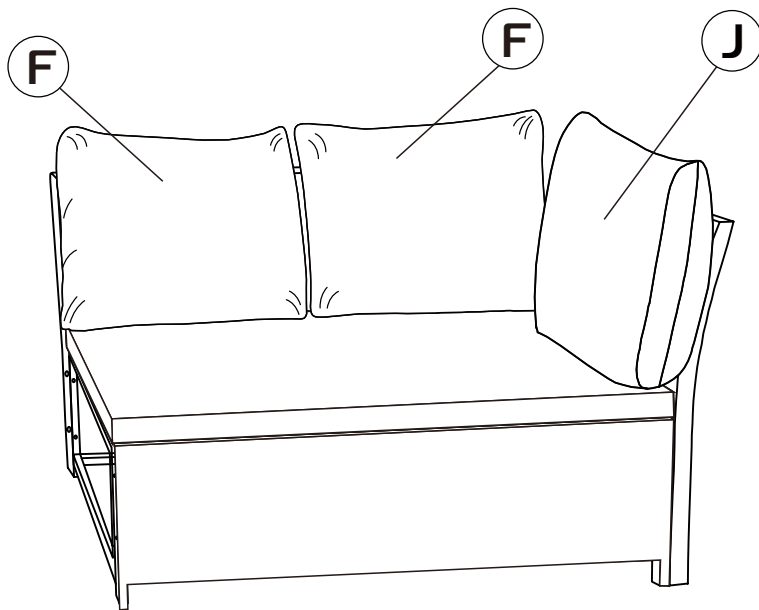

1:1

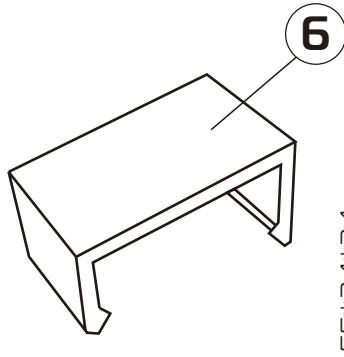

55*34*34mm

x4



1

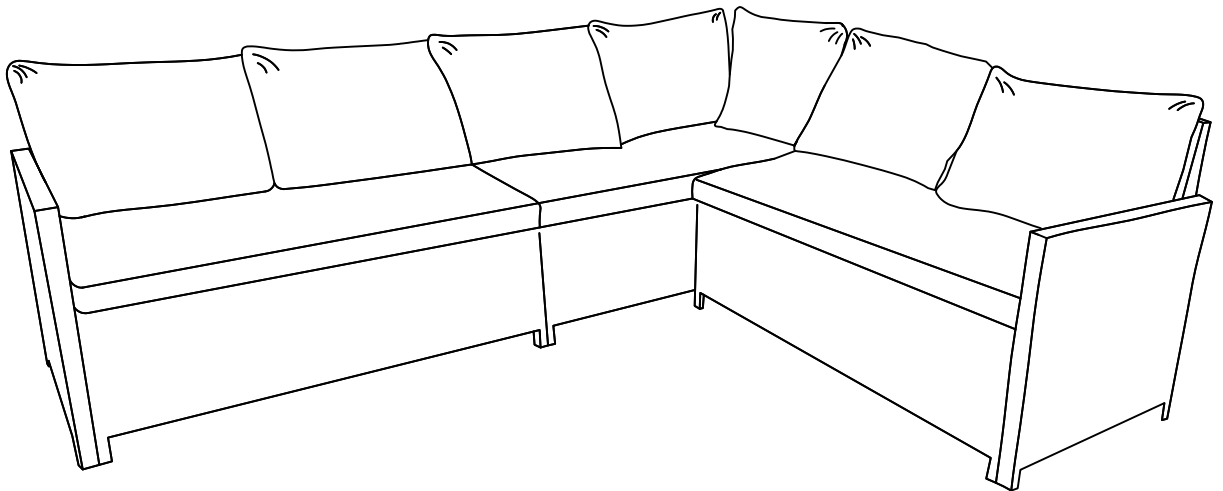
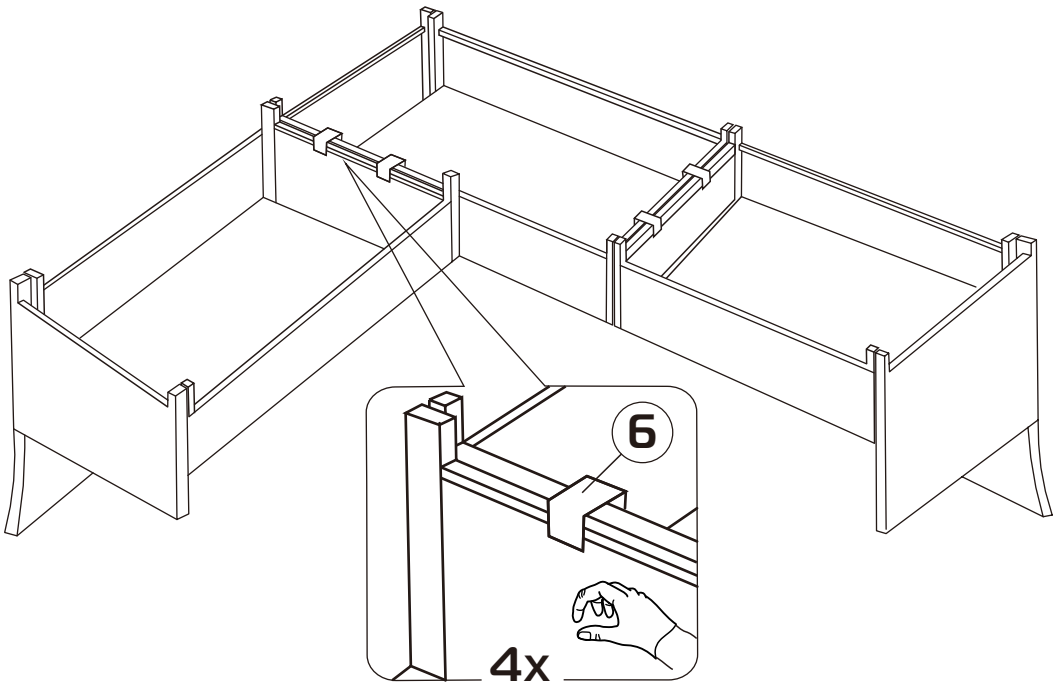

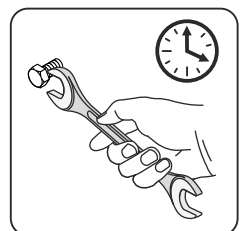
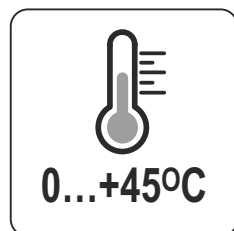
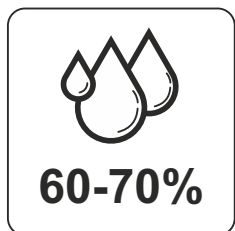
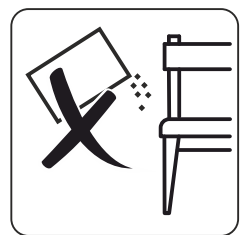
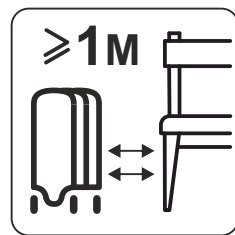
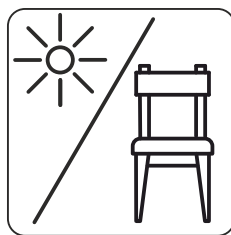
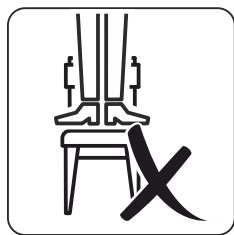
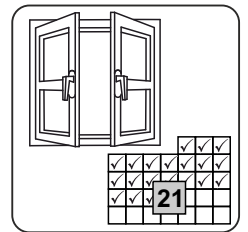
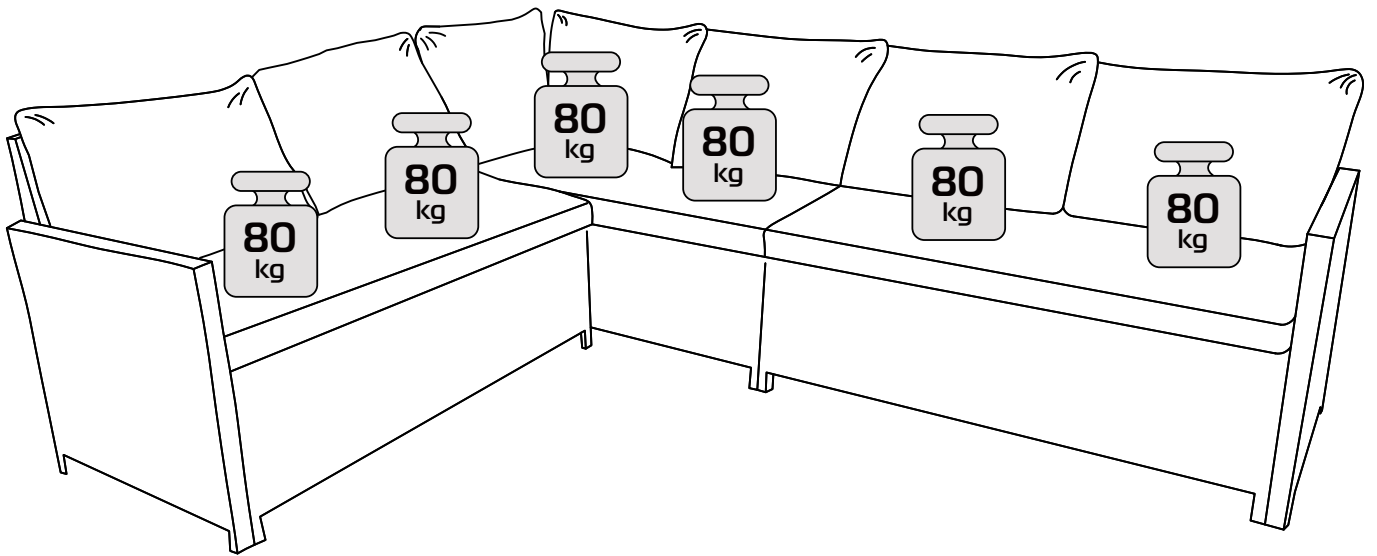

● Rectangle coffee table

1

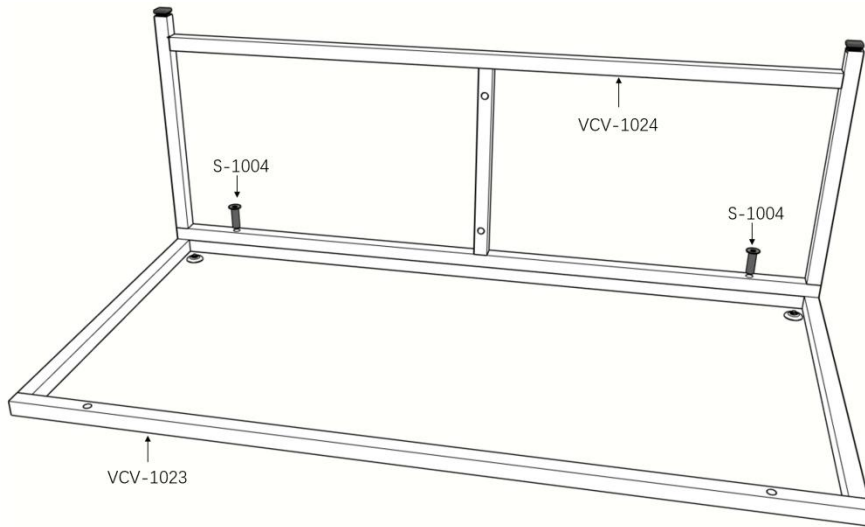

VCV-1023*1, VCV-1024*1, S-1004*2

2

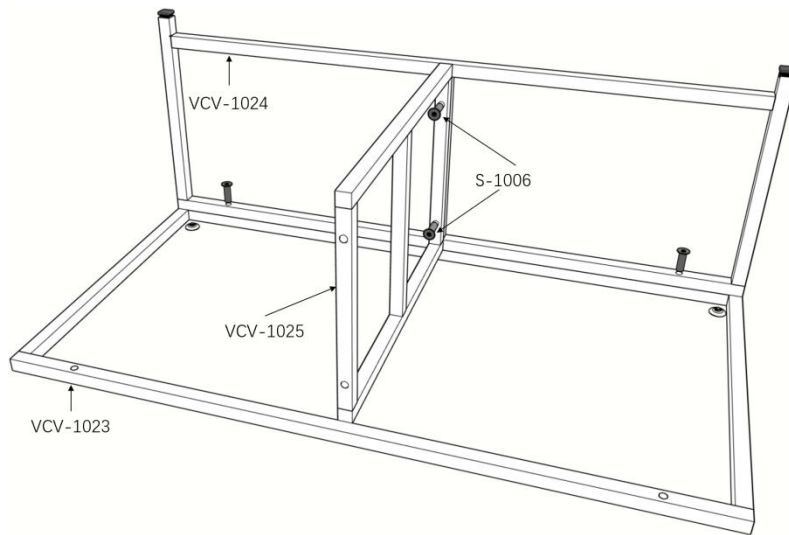

VCV-1025*1, S-1006*2

3

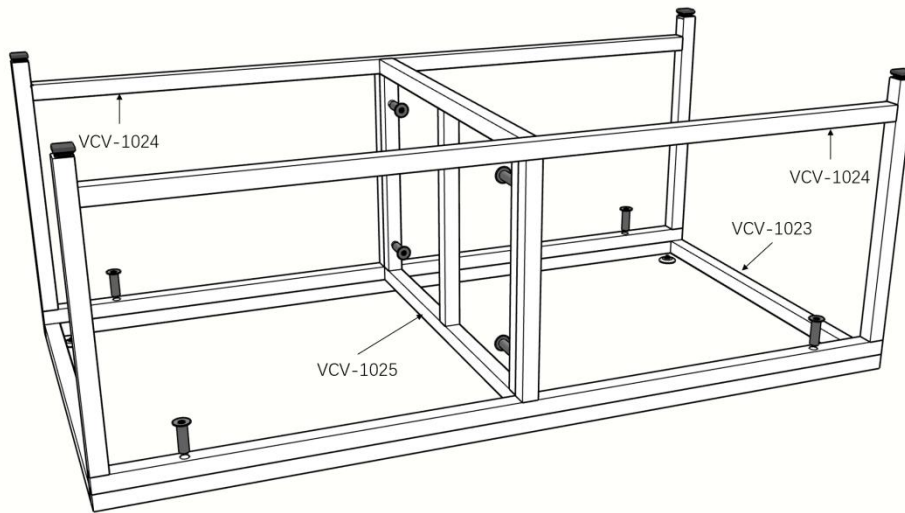

VCV-1024*1, S-1004*2, S-1006*2

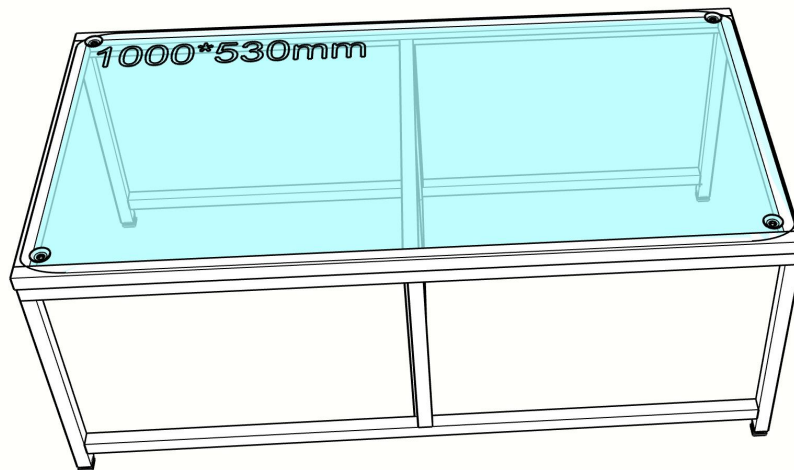

G-1003

Tight all the screws to 60% first then tight to 100%.

Während der Montage alle Schrauben zuerst 60% anziehen, dann zu 100%.

Serrez toutes les vis à 60% d'abord puis serrez à 100%.

Primero apriete los tornillos al 60% y después al 100%.

● Square Stool

1

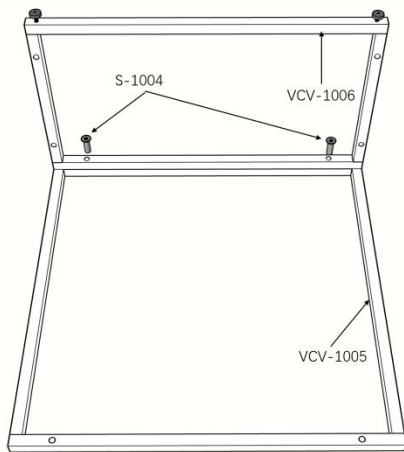

VCV-1005*1, VCV-1006*1, S-1004*2

2

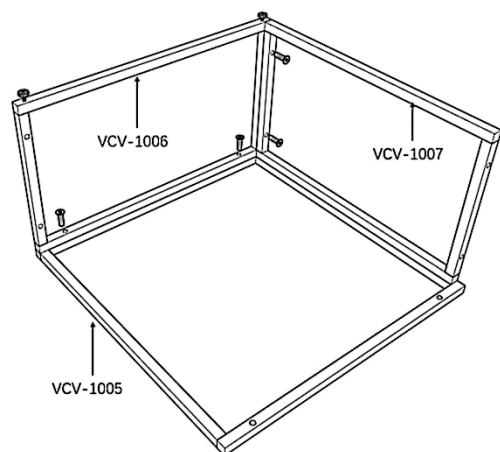

VCV-1007*1, S-1004*2

3

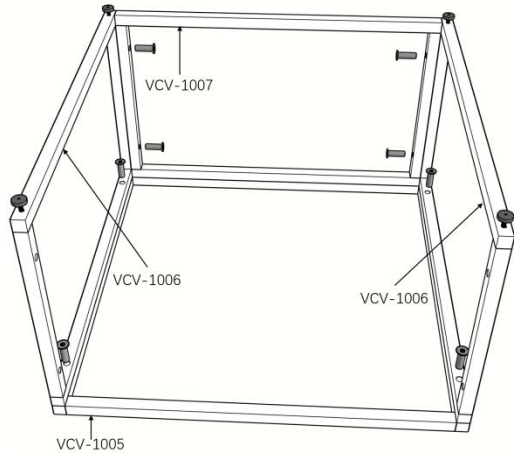

VCV-1006*1, S-1004*4

4

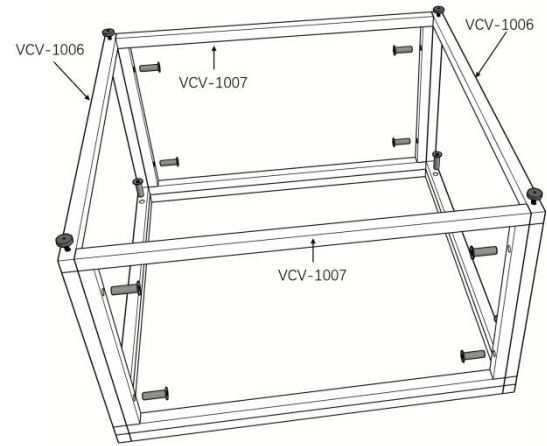

VCV-1007*1, S-1004*4

5

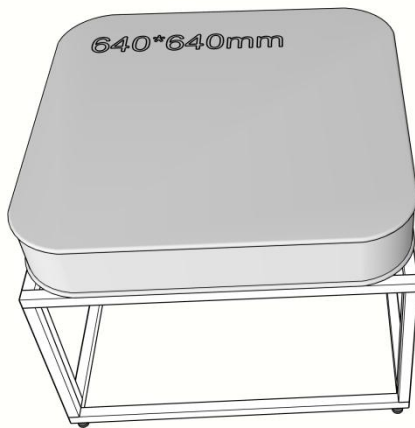

VCV-1010*1

Tight all the screws to 60% first then tight to 100%.

Während der Montage alle Schrauben zuerst 60% anziehen, dann zu 100%.

Serrez toutes les vis à 60% d'abord puis serrez à 100%.

Primero apriete los tornillos al 60% y después al 100%.

