









ASSEMBLY INSTRUCTIONS

HARDWARE LIST			
NO.	PART	DESCRIPTION	Q'TY
A		seat	1
B		right leg	1
C		left leg	1
D	 M6x13mm	short screw	4
E	 M6x50mm	long screw	4
F		cross gasket	1
G		metal gasket	4
H	 5mm	Allen key	1



step 1

step 2

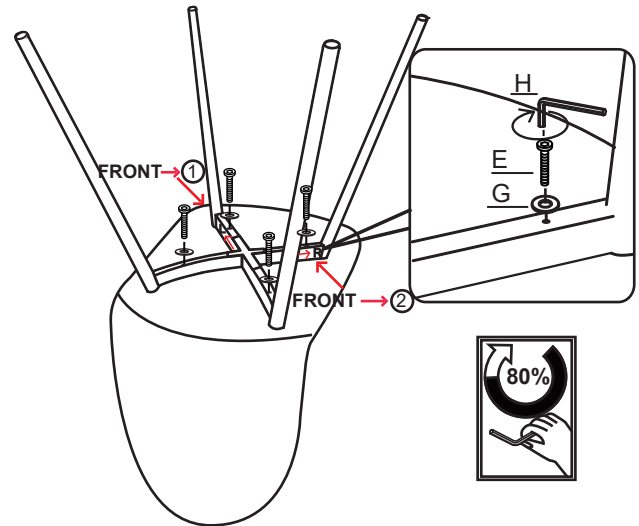
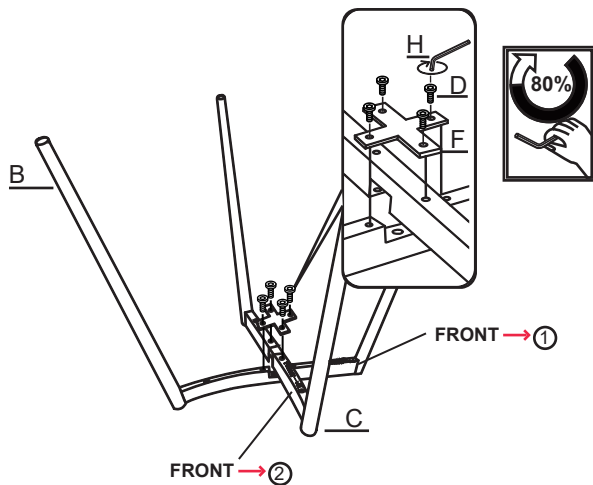

step 3

step 4

Put the chair onto flat place, fully tight all the screws after well adjusted flatness of the chair.



1

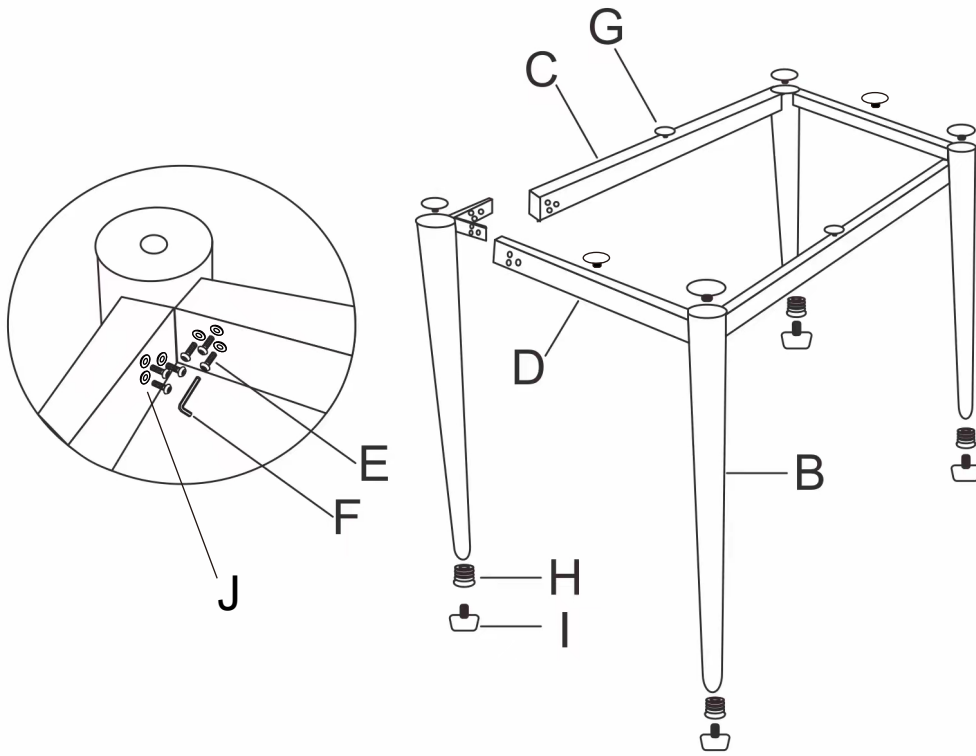

2

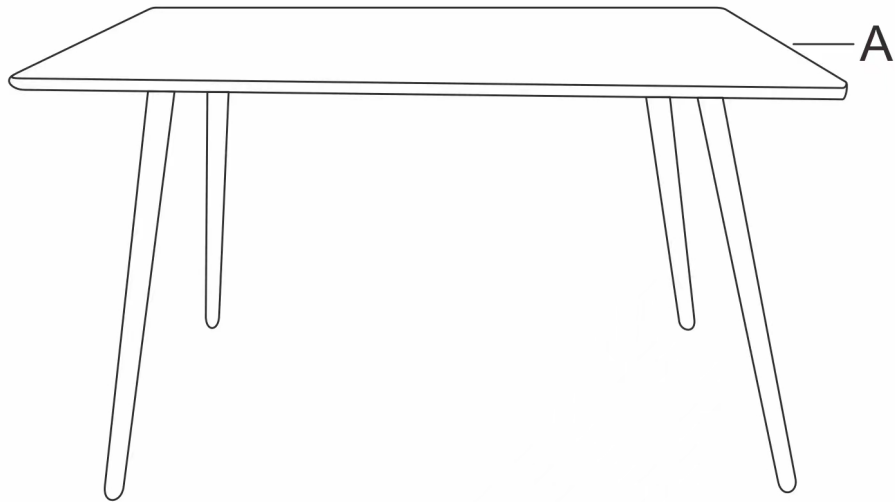

Ax1



Bx4



Cx2



Dx2



Ex24



Fx1



Gx8



Hx4



Ix4



Jx24

